



National Standards Authority of Ireland

IRISH STANDARD

**I.S. 6 : 1974**

ICS 91.140.80  
93.020  
23.040.50

National Standards  
Authority of Ireland  
Dublin 9  
Ireland

Tel: (01) 807 3800  
Tel: (01) 807 3838

## CONCRETE SEWER PIPES

*This Irish Standard was  
published under the  
authority of the National  
Standards Authority of  
Ireland  
and comes into effect on:  
January 21, 1974*

**NO COPYING WITHOUT NSAI  
PERMISSION EXCEPT AS  
PERMITTED BY COPYRIGHT  
LAW**

© NSAI 1974

**Price Code E**

Údarás um Chaighdeán Náisiúnta na hÉireann

This is a free 6 page sample. Access the full version online.

# DECLARATION

OF

SPECIFICATION

ENTITLED

CONCRETE SEWER PIPES

AS

THE IRISH STANDARD SPECIFICATION FOR

CONCRETE SEWER PIPES

---

The Institute for Industrial Research and Standards in exercise of the power conferred by section 20 of the Industrial Research and Standards Act, 1961 (No. 20 of 1961), and with the consent of the Minister for Industry and Commerce, hereby declares as follows:

1. This instrument may be cited as the Standard Specification (Concrete Sewer Pipes) Declaration, 1974.

2. (1) The specification set forth in the Schedule to this declaration is hereby declared to be the standard specification for Concrete Sewer Pipes.

(2) The said standard specification may be cited as Irish Standard 6:1974 or as I.S. 6:1974.

3. (1) The Standard Specification (Concrete Sewer Pipes) Declaration, 1971, is hereby revoked.

(2) Reference in any other standard specification to the Instrument hereby revoked and to Irish Standard 6:1971, thereby prescribed, shall be construed, respectively, as references to this Instrument and to Irish Standard 6:1974.

## SCHEDULE

### Concrete Sewer Pipes

#### SCOPE

1. This specification applies to concrete cylindrical pipes and fittings (i.e. bends and junctions) either reinforced with steel or unreinforced intended to be used for the conveyance under atmospheric pressure of sewage or sewage and surface water drainage. It covers four classes of pipe classified according to their strength.

#### DEFINITIONS

2. For the purpose of this specification the following definitions apply:

(a) *Pipe*. A hollow right cylinder made of concrete, of uniform cross-section throughout its length, except for the joint.

(b) *Reinforced concrete pipe*. A pipe reinforced with steel so as to withstand the crushing test loads specified herein for the particular size and strength class of pipe.

(c) *Barrel*. That portion of a pipe throughout which the internal diameter and wall thickness remain uniform.

(d) *Steel reinforcement*. This consists of hoops either hooked, butt welded or lap welded, or a continuous helix or fabric suitably welded, longitudinals or other means being used to control spacing and shape, and to facilitate handling.

(e) *Rigid spigot and socket joint*. A joint such that the internal and external diameters at one end are enlarged to form a socket into which the spigot end of a similar pipe or fitting can enter to form a joint which is sealed by the use of cement mortar or other suitable material.

(f) *Gasket type flexible spigot and socket joint*. A joint such that the internal and external diameters at one end are enlarged to form a socket into which the spigot end of a similar pipe or fitting can enter to form a joint in which a gasket of rubber or equally suitable material in the form of one or more rings is used in such a way that it is adequately compressed to seal the joint.

(g) *Gasket type flexible rebated joint.* A joint such that a gasket of rubber or equally suitable material is used in the form of one or more rings to act as a seal, but within the limits of the wall thickness and without increasing the external diameter at one end of the pipe or fitting.

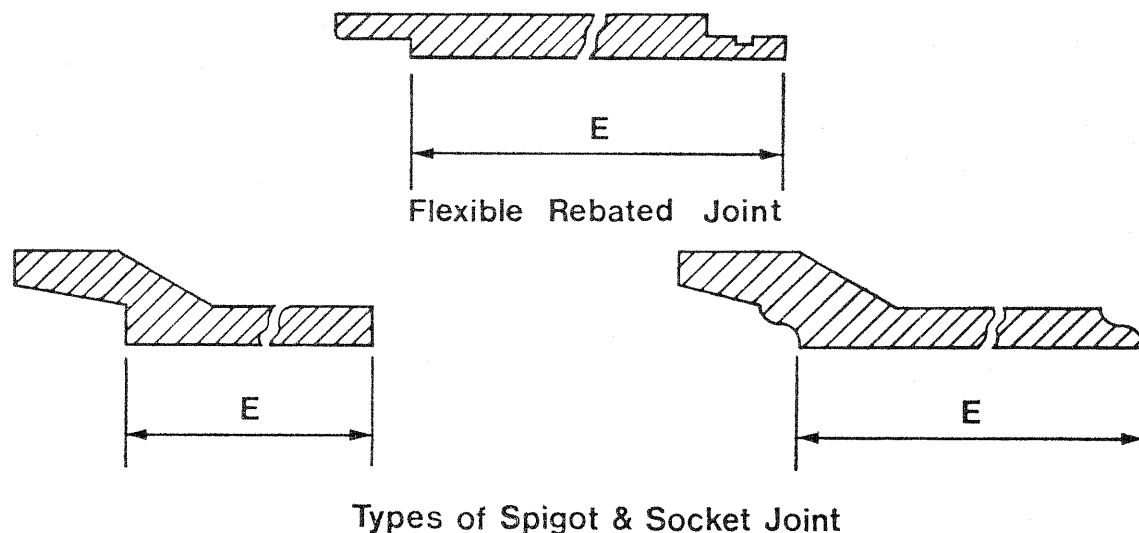

Fig. 1

(h) *Nominal length.* The nominal length of a pipe shall be its effective length measured as illustrated in Fig. 1.

The nominal length of a bend shall be its effective length measured along the centre line as indicated in Fig. 2.

The nominal length of a junction shall be its effective length measured as illustrated in Fig. 3.

#### CLASS OF PIPE

3. The pipes shall be of one of the four classes for which the strengths are set out in Table 2. Class N pipes may be termed 'Normal Pipes' and Classes L, M and H 'Extra Strength Pipes'.

#### CEMENT

4. The cement used in the manufacture of the pipes and fittings shall comply with the requirements of Irish Standard 1, Portland Cement. For pipes and fittings not containing steel reinforcement extra rapid hardening Portland cement containing calcium chloride may be used provided that the total amount of calcium chloride present in the concrete does not exceed  $1\frac{1}{2}$  per cent by weight of cement.

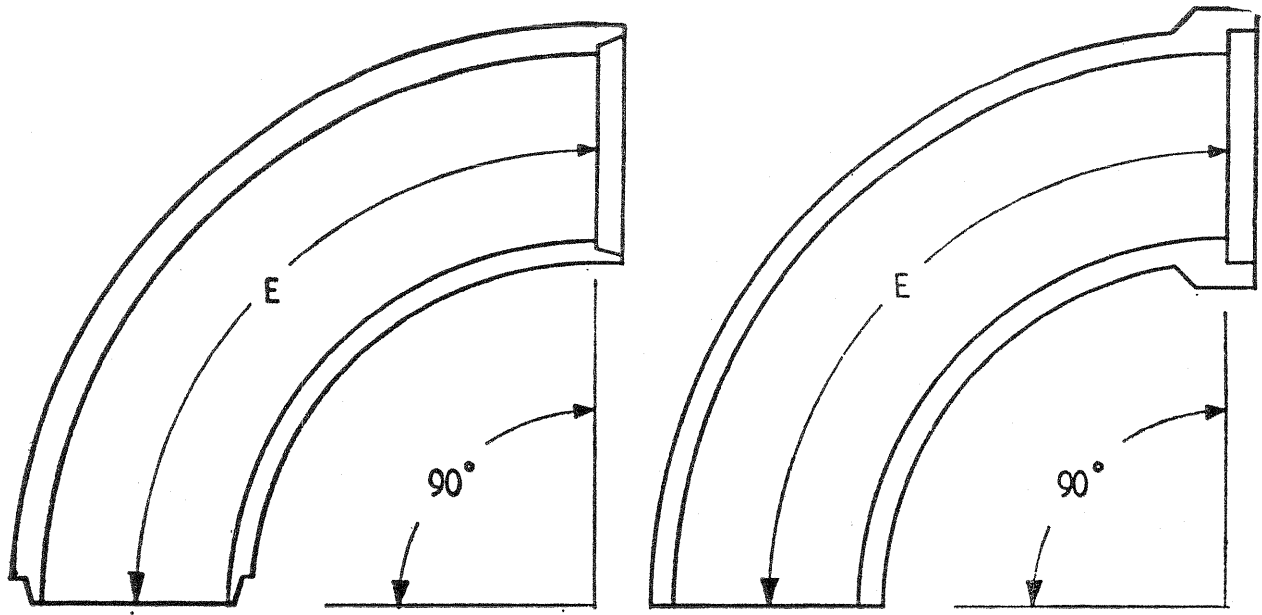

90° Bends

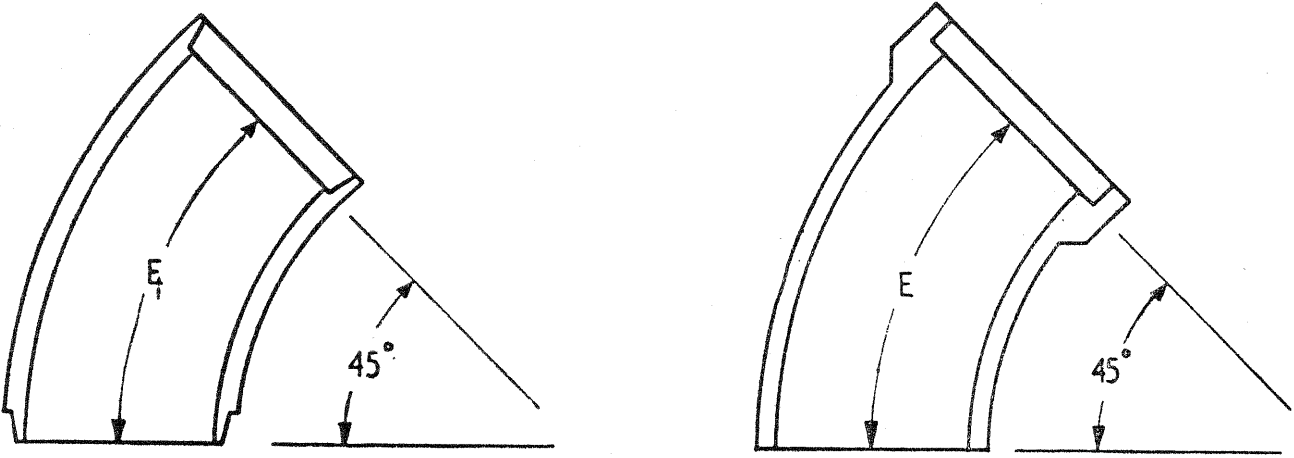

45° Bends

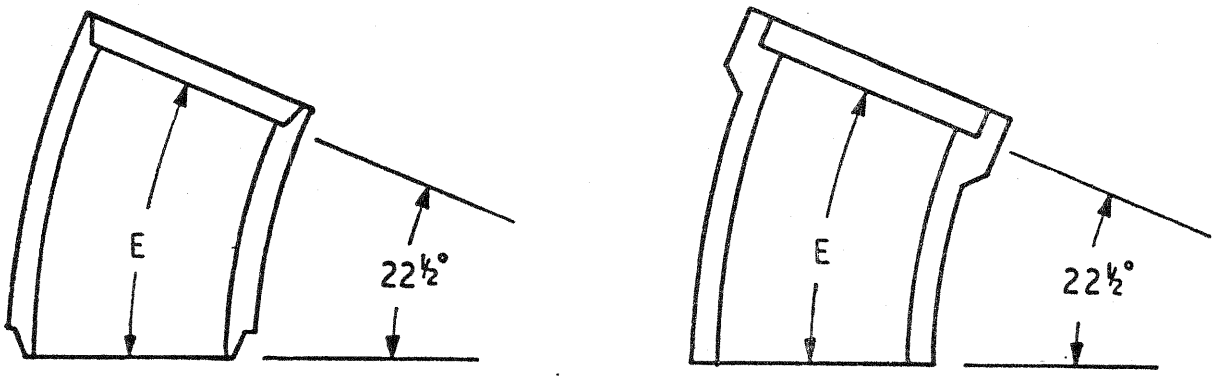

22½° Bends

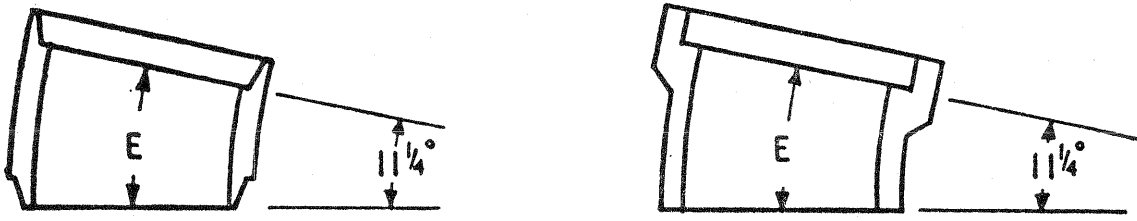

11¼° Bends

**Fig. 2 Nominal length of bends**  
(Diagrammatic illustrations, not designs of bends)

This is a free preview. Purchase the entire publication at the link below:

## **I.S. 6 : 1974 : EN : COMBINED PDF**

- 
- ⊙ Looking for additional Standards? Visit SAI Global Infostore
  - ⊙ Learn about LexConnect, All Jurisdictions, Standards referenced in Australian legislation
- 

Need to speak with a Customer Service Representative - Contact Us